

## NQR 500/NQR 525 NQR 500/NQR 525 CREW



### WEIGHT RATINGS

|                      |                     |
|----------------------|---------------------|
| <b>GVM</b>           | 8,700 / 5,995 kg    |
| <b>GCM *CREW CAB</b> | 12,200 / 11,000 kg* |

### ENGINE

|               |                            |
|---------------|----------------------------|
| <b>POWER</b>  | 140 kW @ 2,600 rpm         |
| <b>TORQUE</b> | 513 Nm @ 1,600 - 2,600 rpm |

### TRANSMISSION

|   |
|---|
| 6 speed manual transmission (MT)            |
| 6 speed automated manual transmission (AMT) |

\* Refer to back page for detailed weight rating information

| INTELLIGENT SAFETY   |   |              |
|--|---|--------------|
| <b>ACTIVE SAFETY<br/>ADVANCED DRIVER ASSISTANCE SYSTEMS (ADAS)</b> | Advanced Emergency Braking                                  | <b>(AEB)</b> |
|  | Forward Collision Warning                                   | <b>(FCW)</b> |
|  | Distance Warning System                                     | <b>(DWS)</b> |
|  | Lane Departure Warning                                      | <b>(LDW)</b> |
|  | Traffic Movement Warning                                    | <b>(TMW)</b> |
|  | Electronic Stability Control                                | <b>(ESC)</b> |
|  | Anti Skid Regulator   | <b>(ASR)</b> |
|  | Anti Lock Braking System                                    | <b>(ABS)</b> |
|  | Customisable Speed Limiter                                  | <b>(CSL)</b> |
|  | Hill Start Aid (MT only)                                    | <b>(HSA)</b> |
|  | Automatic Lighting System (Front and Rear)                  | <b>(ALS)</b> |
| <b>PASSIVE SAFETY<br/>CABIN OCCUPANT SAFETY SYSTEMS (COSS)</b>     | Cab Tilt Warning (except crew cab)                          | <b>(CTW)</b> |
|  | Driver and front passenger airbags                          |              |
|  | Driver and front left hand passenger seatbelt pretensioners |              |
|  | ECE-R29 cab with side anti-intrusion beams                  |              |
|  | Handsfree functions on steering wheel                       |              |
| Door mounted cornering lamps                                       |   |              |

| ISUZU WARRANTY COVER |                              |
|----------------------|------------------------------|
| <b>WARRANTY</b>      | 5 Year / 250,00 km Warranty# |

| ENGINE                   |  |
|--------------------------|--|
| <b>DESCRIPTION</b>       | Isuzu 4HK1-TCC   |
| <b>TYPE</b>              | 4 cylinder 16 valve SOHC   |
| <b>DISPLACEMENT</b>      | 5,193 cc   |
| <b>COMPRESSION RATIO</b> | 17.5:1   |
| <b>BORE X STROKE</b>     | 115 mm x 125 mm  |
| <b>POWER</b>             | 140 kW (190PS) @ 2,600 rpm (DIN NET)   |
| <b>TORQUE</b>            | 513 Nm @ 1,600 - 2,600 rpm (DIN NET)   |
| <b>INDUCTION</b>         | Electronically controlled variable nozzle turbocharger with air-to-air intercooler           |
| <b>FUEL INJECTION</b>    | Direct injection high pressure common rail   |
| <b>EMISSION CONTROL</b>  | Cooled EGR with exhaust Diesel Oxidation Catalyst (DOC). ADR 80/03 (Euro V / EEV) compliant. |

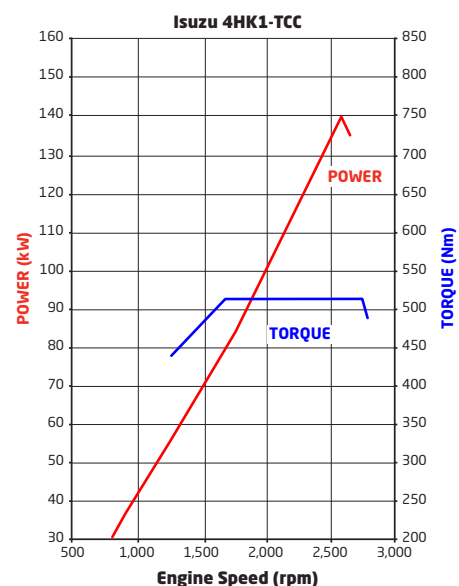

| CLUTCH |  |
|--------|--|
| MT     | <b>Type:</b> Single plate with auto adjusting hydraulic control and vacuum assistance                    |
|        | <b>Clutch Plate Diameter:</b> 325 mm   |
|        | <b>Clutch lining area:</b> 966 cm <sup>2</sup>   |
| AMT    | <b>Type:</b> Fully automated electro/hydraulically controlled wet clutch and fluid coupling with lock up |

| TRANSMISSION |   |       |       |       |       |       |     |     |       |       |       |       |       |       |       |
|--------------|---|-------|-------|-------|-------|-------|-----|-----|-------|-------|-------|-------|-------|-------|-------|
| MT           | <b>Description:</b> Isuzu MZZ-6F  |       |       |       |       |       |     |     |       |       |       |       |       |       |       |
|              | <b>Type:</b> 6 speed manual. Syncromesh on gears 1-6.   |       |       |       |       |       |     |     |       |       |       |       |       |       |       |
|              | <b>Ratios:</b>  |       |       |       |       |       |     |     |       |       |       |       |       |       |       |
|              | <table border="1"> <thead> <tr> <th>1ST</th> <th>2ND</th> <th>3RD</th> <th>4TH</th> <th>5TH</th> <th>6TH</th> <th>REV</th> </tr> </thead> <tbody> <tr> <td>6.369</td> <td>3.767</td> <td>1.966</td> <td>1.355</td> <td>1.000</td> <td>0.782</td> <td>6.369</td> </tr> </tbody> </table> | 1ST   | 2ND   | 3RD   | 4TH   | 5TH   | 6TH | REV | 6.369 | 3.767 | 1.966 | 1.355 | 1.000 | 0.782 | 6.369 |
| 1ST          | 2ND   | 3RD   | 4TH   | 5TH   | 6TH   | REV   |     |     |       |       |       |       |       |       |       |
| 6.369        | 3.767   | 1.966 | 1.355 | 1.000 | 0.782 | 6.369 |     |     |       |       |       |       |       |       |       |
| AMT          | <b>Description:</b> Isuzu MZZ-6F  |       |       |       |       |       |     |     |       |       |       |       |       |       |       |
|              | <b>Type:</b> 6 speed with both fully automatic and clutchless manual operation modes  |       |       |       |       |       |     |     |       |       |       |       |       |       |       |
|              | <b>Ratios:</b>  |       |       |       |       |       |     |     |       |       |       |       |       |       |       |
|              | <table border="1"> <thead> <tr> <th>1ST</th> <th>2ND</th> <th>3RD</th> <th>4TH</th> <th>5TH</th> <th>6TH</th> <th>REV</th> </tr> </thead> <tbody> <tr> <td>6.369</td> <td>3.767</td> <td>1.966</td> <td>1.355</td> <td>1.000</td> <td>0.782</td> <td>6.369</td> </tr> </tbody> </table> | 1ST   | 2ND   | 3RD   | 4TH   | 5TH   | 6TH | REV | 6.369 | 3.767 | 1.966 | 1.355 | 1.000 | 0.782 | 6.369 |
| 1ST          | 2ND   | 3RD   | 4TH   | 5TH   | 6TH   | REV   |     |     |       |       |       |       |       |       |       |
| 6.369        | 3.767   | 1.966 | 1.355 | 1.000 | 0.782 | 6.369 |     |     |       |       |       |       |       |       |       |
|              | <b>Power Take Off facility:</b> Provision on LHS of transmission case. Drive from counter gear.   |       |       |       |       |       |     |     |       |       |       |       |       |       |       |

| AXLES |   |
|-------|---|
| FRONT | <b>Description:</b> Isuzu F031                                  |
|       | <b>Type:</b> Reverse Elliot I-beam                              |
|       | <b>Capacity:</b> 3,100 kg                                       |
| REAR  | <b>Description:</b> Isuzu R066                                  |
|       | <b>Type:</b> Full floating banjo with four differential pinions |
|       | <b>Capacity:</b> 6,600 kg                                       |
|       | <b>Ratio:</b> 4.556 (MT), 4.300 (AMT)                           |

| SUSPENSION |  |
|------------|--|
| FRONT      | <b>Single cab:</b> Single stage alloy steel taper leaf springs<br><b>Crew cab:</b> Single stage alloy steel multi leaf springs |
|            | Double acting hydraulic shock absorbers  |
| REAR       | Multi leaf main, multi leaf helper spring  |
|            | Double acting hydraulic shock absorbers. Stabiliser bar.   |

| BRAKES                 |  |
|------------------------|--|
| <b>TYPE</b>            | Ventilated disc/disc with dual circuit hydraulic control, integrated boost assist and electronic brake force distribution (EBD). |
| <b>DIAMETER FRONT</b>  | 363 mm   |
| <b>DIAMETER REAR</b>   | 348 mm   |
| <b>PARK BRAKE</b>      | 203 mm diameter drum mounted on rear of transmission   |
| <b>AUXILIARY BRAKE</b> | Vacuum controlled exhaust brake  |

| STEERING                  |  |
|---------------------------|--|
| <b>TYPE</b>               | Power assisted recirculating ball        |
| <b>GEAR RATIO</b>         | 20.9                                     |
| <b>TURNS LOCK TO LOCK</b> | 5.4                                      |
| <b>WHEEL LOCK ANGLE</b>   | 43° (inside wheel) / 33° (outside wheel) |

| WHEELS & TYRES |  |
|----------------|--|
| FRONT          | <b>Wheels:</b> 19.5 x 6.00 six stud steel                |
|                | <b>Tyres:</b> 225/70R 19.5 125/123L Bridgestone Tubeless |
|                | <b>Steer axle tyre rating:</b> 3,300 kg                  |
| REAR           | <b>Wheels:</b> 19.5 x 6.00 six stud steel                |
|                | <b>Tyres:</b> 225/70R 19.5 125/123L Bridgestone Tubeless |
|                | <b>Drive axle tyre rating:</b> 6,200 kg                  |
| SPARE          | 1 frame mounted spare wheel and tyre assembly            |

| CHASSIS FRAME     |  |
|-------------------|--|
| <b>TYPE</b>       | Cold rivetted ladder frame. SAPH440 steel sidemembers. Parallel side rails and rivetless top flange. |
| <b>DIMENSIONS</b> | <b>Side rail (mm):</b> 216 x 70 x 6.0<br><b>Rear frame width (mm):</b> 850                           |

| FUEL TANK       |                               |
|-----------------|-------------------------------|
| <b>TYPE</b>     | Frame mounted steel fuel tank |
| <b>CAPACITY</b> | 140L                          |
| <b>FUEL CAP</b> | Lockable                      |

| ELECTRICAL SYSTEM    |  |
|----------------------|--|
| <b>TYPE</b>          | 24 volt  |
| <b>ALTERNATOR</b>    | 90 amp   |
| <b>STARTER MOTOR</b> | 4.0 kW   |
| <b>BATTERY</b>       | 2 x 80D26L (630 CCA) batteries connected in series |

| CABIN GENERAL FEATURES   |   |
|--------------------------|---|
| <b>ENGINE ACCESS</b>     | <b>Single cab:</b> Manual cab tilt with torsion bar assistance <b>AH and crew cab:</b> Access hatch under driver's seat and tiltable front passenger seat |
| <b>STEPS</b>             | Heavy duty anti-slip steps  |
| <b>DOORS</b>             | 90° opening internally reinforced front doors   |
| <b>MIRRORS</b>           | Heated and powered exterior main mirrors with flat glass and additional independantly adjustable convex "spot" mirrors                                    |
| <b>WIPERS</b>            | Two speed windscreen wipers with intermittent wipe mode   |
| <b>EXTERIOR LIGHTING</b> | Multi-reflector halogen headlamps<br>Front foglamps   |
| <b>AUDIBLE WARNING</b>   | Reverse alarm   |
| <b>GRILLE</b>            | Cabin coloured  |
| <b>SECURITY</b>          | Central locking with remote keyless entry and immobiliser   |

| INSTRUMENTATION                  |  |
|----------------------------------|--|
| <b>MULTI INFORMATION DISPLAY</b> | AEB, FCW, DWS, LDW, TMW systems activation alerts                  |
|                                  | CTW indicator (except crew cab)                                    |
|                                  | Low engine oil level alert (activated when oil pan < 71% capacity) |
|                                  | Vehicle systems status   |
|                                  | Low fuel level alert   |
|                                  | Fuel consumption information                                       |
|                                  | Service interval alerts  |
| <b>GENERAL INSTRUMENTATION</b>   | Hourmeter  |
|                                  | Adjustable vehicle speed warning                                   |
|                                  | Speedometer and tachometer   |
|                                  | Digital odometer with integrated dual tripmeters                   |
|                                  | Engine coolant temperature and fuel level gauges                   |

| CABIN INTERIOR            |   |
|---------------------------|---|
| <b>SEATING</b>            | <b>Single cab:</b> Driver's bucket seat equipped with mechanical suspension and weight adjustment to 130 kg |
|                           | <b>AH and crew cab:</b> Driver's bucket seat  |
|                           | Passenger bench seat with 2 seat capacity   |
|                           | <b>Crew cab:</b> Rear bench seat with 4 seat capacity   |
| <b>SEATBELTS</b>          | 3-point lap sash seatbelts in all outboard seating positions. Centre seat lap belts.                        |
| <b>STEERING COLUMN</b>    | Tilt/telescopic adjustable  |
| <b>ENTRY ASSIST GRIPS</b> | Door and roof pillar mounted  |
|                           | <b>Crew cab:</b> Full width rear grab rail  |
| <b>DOOR WINDOWS</b>       | Electric control  |
| <b>STORAGE</b>            | Overhead shelf  |
|                           | Twin cup holders  |
|                           | Front centre console box and storage tray   |
|                           | Front door pockets  |
| <b>POWER OUTLET</b>       | 24V cigarette lighter   |
| <b>AIRCONDITIONING</b>    | Manual control  |
| <b>INTERIOR LIGHTING</b>  | <b>Single cab:</b> Fluorescent lamp <b>Crew cab:</b> Standard lamp  |



Crew cabin rear

| AUDIO VISUAL UNIT                |  |
|----------------------------------|--|
| <b>SCREEN TYPE</b>               | 6.2" LCD with capacitive touch   |
| <b>OPERATING SYSTEM</b>          | Android  |
| <b>RADIO</b>                     | AM/FM  |
| <b>INTERNAL STORAGE CAPACITY</b> | 32GB   |
| <b>OTHER CAPABILITY</b>          | Provision for external camera inputs, navigation, reverse sensors and tyre pressure monitoring |



| DRIVER CONTROLS                |  |
|--------------------------------|--|
| <b>SAFETY SYSTEMS</b>          | AEB on/off, DWS on/off/sensitivity adjust, LDW on/off/sensitivity adjust, TMW on/off, ESC & ASR on/off, headlamps and ALS on/off, HSA on/off/sensitivity adjust (MT only). |
| <b>ENGINE</b>                  | Idle speed control   |
|                                | Cruise control   |
| <b>TRANSMISSION (AMT ONLY)</b> | Slow/fast gear engagement control, 1st gear start and normal/economy gear selection modes  |
|                                | Gear selection control with P-R-N-D and sequential shift positions   |
| <b>GENERAL CONTROLS</b>        | Windscreen wipers (2 speed and intermittent modes), washers, exhaust brake, turn signals   |



AMT model shown

# NQR 500/NQR 525 NQR 500/NQR 525 CREW

# ISUZU TRUCKS

| WEIGHTS (kg)               |               |                 |                            |       |                      |       |       |
|----------------------------|---------------|-----------------|----------------------------|-------|----------------------|-------|-------|
| MODELS                     | RATINGS*      |                 | LOADING LIMIT* (at ground) |       | CAB CHASSIS WEIGHT # |       |       |
|                            | GVM           | GCM             | FRONT                      | REAR  | FRONT                | REAR  | TOTAL |
| NQR 500 / NQR 525 MWB      | 8,700 / 5,995 | 12,200          | 3,100                      | 6,200 | 1,840                | 1,010 | 2,850 |
| NQR 500 / NQR 525 AMT      | 8,700 / 5,995 | 12,200          | 3,100                      | 6,200 | 1,840                | 1,010 | 2,850 |
| NQR 500 / NQR 525 AMT      | 8,700 / 5,995 | 12,200          | 3,100                      | 6,200 | 1,855                | 1,000 | 2,855 |
| NQR 500 / NQR 525 L        | 8,700 / 5,995 | 12,200          | 3,100                      | 6,200 | 1,910                | 1,030 | 2,940 |
| NQR 500 / NQR 525 AMT L    | 8,700 / 5,995 | 12,200          | 3,100                      | 6,200 | 1,910                | 1,030 | 2,940 |
| NQR 500 / NQR 525 CREW     | 8,700 / 5,995 | 12,200 / 11,000 | 3,100                      | 6,200 | 2,070                | 1,060 | 3,130 |
| NQR 500 / NQR 525 AMT CREW | 8,700 / 5,995 | 12,200 / 11,000 | 3,100                      | 6,200 | 2,070                | 1,060 | 3,130 |

\* Vehicle ratings and axle weight limits are subject to government regulatory requirements and weight distribution analysis. Consult your Isuzu dealer to select the correct vehicle for your specific application. # Cab chassis only as supplied and including 10 litres of fuel.

| DIMENSIONS (mm)        |       |       |       |       |       |       |       |       |       |               |               |               | (m)                         |
|------------------------|-------|-------|-------|-------|-------|-------|-------|-------|-------|---------------|---------------|---------------|-----------------------------|
| MODELS                 | WB    | OAL   | FOH   | ROH   | EA    | CE    | RT    | ORT   | CH    | FFA (unladen) | RFA (unladen) | RFH (unladen) | TURNING CIRCLE kerb to kerb |
| NQR 500 / NQR 525      | 3,365 | 5,985 | 1,100 | 1,510 | 2,680 | 4,302 | 1,670 | 2,150 | 2,310 | 710           | 815           | 855           | 12.4                        |
| NQR 500 / NQR 525 L    | 4,475 | 7,804 | 1,100 | 2,219 | 3,790 | 6,121 | 1,670 | 2,150 | 2,310 | 710           | 815           | 865           | 16.4                        |
| NQR 500 / NQR 525 CREW | 4,475 | 7,804 | 1,100 | 2,219 | 2,810 | 5,120 | 1,670 | 2,150 | 2,310 | 710           | 820           | 875           | 16.4                        |

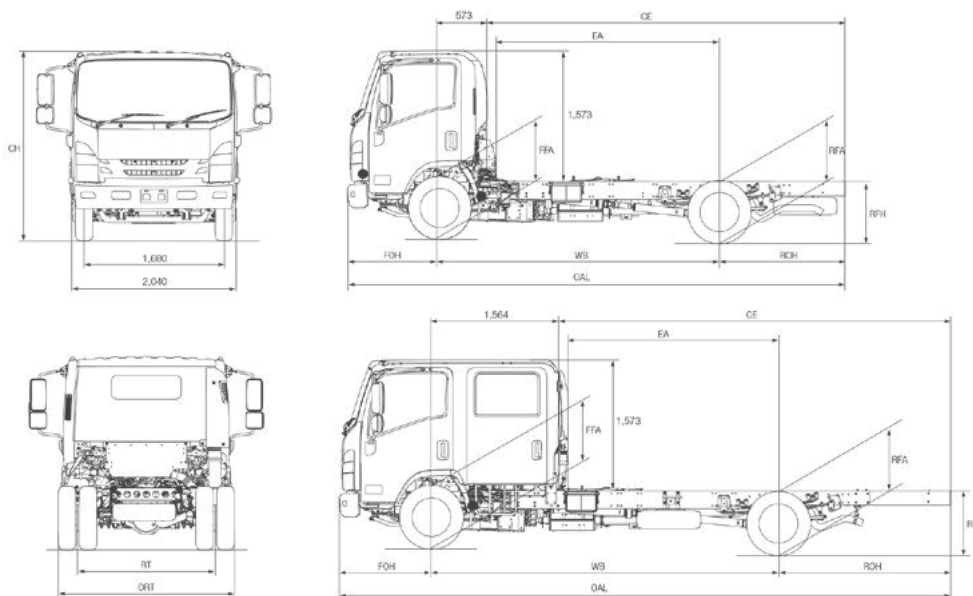

| PERFORMANCE (calculated - typical paved road) |                 |   |   |                                    |
|---|-----------------|---|---|------------------------------------|
| MODELS  | GVM             | GEARED SPEED* (top gear at peak power engine rpm) | LOW SPEED GRADEABILITY (lowest forward gear assuming no wheel slip) | ENGINE SPEED (top gear at 90 km/h) |
| NQR 525                                       | At 5,995 kg GVM | 121 km/h @ 2,600 RPM                              | 57%   | 2,177 rpm                          |
| NQR 500                                       | At 8,700 kg GVM | 121 km/h @ 2,600 RPM                              | 44%   | 2,177 rpm                          |
| NQR 525 AMT                                   | At 5,995 kg GVM | 116 km/h @ 2,600 RPM                              | 54%   | 2,055 rpm                          |
| NQR 500 AMT                                   | At 8,700 kg GVM | 116 km/h @ 2,600 RPM                              | 41%   | 2,055 rpm                          |

\* Maximum speed achievable depends on vehicle frontal area as well as other factors. Consult your Isuzu dealer for more detailed information.

| ORDER CODES |        | ORDER CODES        |        |
|-------------|--------|--------------------|--------|
| MODELS      | CODES  | MODELS             | CODES  |
| NQR 500     | NQ0118 | NQR 500 L AMT      | NQ0418 |
| NQR 525     | NQ1013 | NQR 525 L AMT      | NQ1313 |
| NQR 500 AMT | NQ0218 | NQR 500 CREW       | NQ0518 |
| NQR 525 AMT | NQ1113 | NQR 525 CREW       | NQ1513 |
| NQR 500 L   | NQ0318 | NQR 500 CREW (AMT) | NQ0618 |
| NQR 525 L   | NQ1213 | NQR 525 CREW (AMT) | NQ1713 |

# Total 5 Year Warranty, including Base Warranty (36 months / 100,000kms) and Additional Warranty (24 months / 150,000kms), cover is 60 months or 250,000kms, whichever comes first. To qualify for Additional Warranty, all scheduled servicing during the Base and Additional Warranty periods (ie. the total 60 months) must be performed by an authorised Isuzu service dealer from the date of delivery to the first customer. If scheduled servicing is performed by unauthorised service providers, only the Base Warranty will apply. For VL24 NPR Tipper models, additional Warranty applies to the cab & chassis only. Tipper bodies are excluded from Additional Warranty. These are covered by Base Warranty only. Cab Perforation Corrosion is limited to 36 months / unlimited kms on all models. It is not included as part of Additional Warranty.

The information in this spec sheet was correct at time of printing, but all measurements, specifications and equipment are subject to change without notice. Some equipment may have been changed and/or is available at extra cost. Isuzu New Zealand (INZ) may make changes at any time without notice, in prices, colours, materials, equipment and models. INZ makes all reasonable attempts to ensure the availability of all vehicles and equipment. The information in this spec sheet is general in nature. Your Isuzu dealer can confirm all measurements, specifications and vehicle / equipment availability upon request. To the extent permitted by the law, INZ is not liable to any person as result of reliance on the content of this spec sheet.