



All images displayed in this document are for illustrative purposes only.

Specification Guide

FTS 150.26

FTS 150.26 Crew

Weight Rating

GVM 15,000

GCM 18,500

Engine

Power 191 kW @ 2,070 rpm

Torque 883 Nm @ 1000 - 2070 rpm

Transmission

6 speed Allison automatic transmission (AT)

Wheelbase

4,250 mm

Key Features

- ADR 80/04 (Euro VI) Compliant
- Advanced Emergency Braking (AEB)
- Lane Departure Warning (LDW)
- Electronic Stability Control (ESC)
- ECE-R29 cab with side anti-intrusion beams
- Isri 6860/875 NTS2 Air Suspension Driver's Seat
- Bi-LED Headlamps with Daytime Running Lamps

NOTE: This spec sheet is indicative only - certain specifications still to be confirmed.



Truck Finder

Scan to search, view and download full spec sheets for all Isuzu truck models.

ISUZU
TRUCKS

Driveline

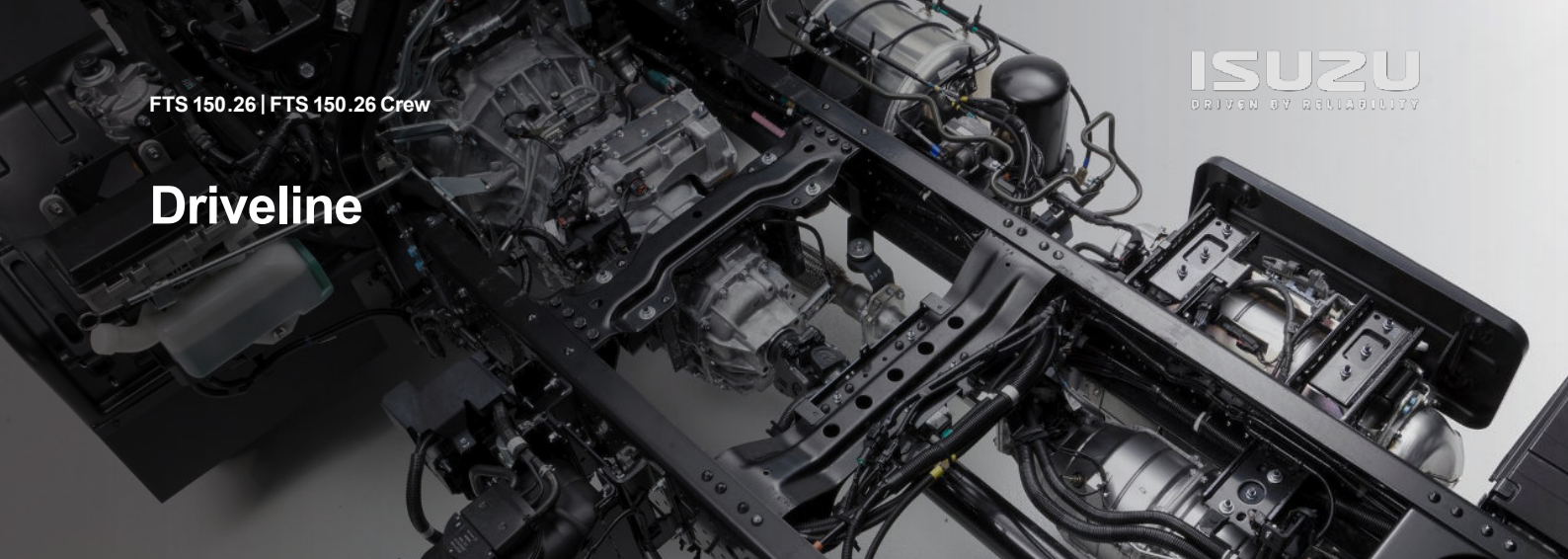

Engine

Description	Isuzu DB6A-TCN
Type	6 cylinder
Power	191 kW (260PS) @ 2,070 rpm
Torque	883 Nm @ 1,000 - 2,070 rpm
Displacement	6,690 cc
Bore x Stroke	107 mm x 124 mm
Induction	Turbocharger with air-to air intercooler
Fuel Injection	Direct injection high pressure common rail system
Emission Standard	ADR 80/04 (Euro VI) compliant
Emission Control	SCR (Selective Catalytic Reduction) DPD (Diesel Particulate Diffuser)
Auxiliary Brake	Engine Compression Brake (I-Brake)

DB6A-TCN 260PS Euro-VI

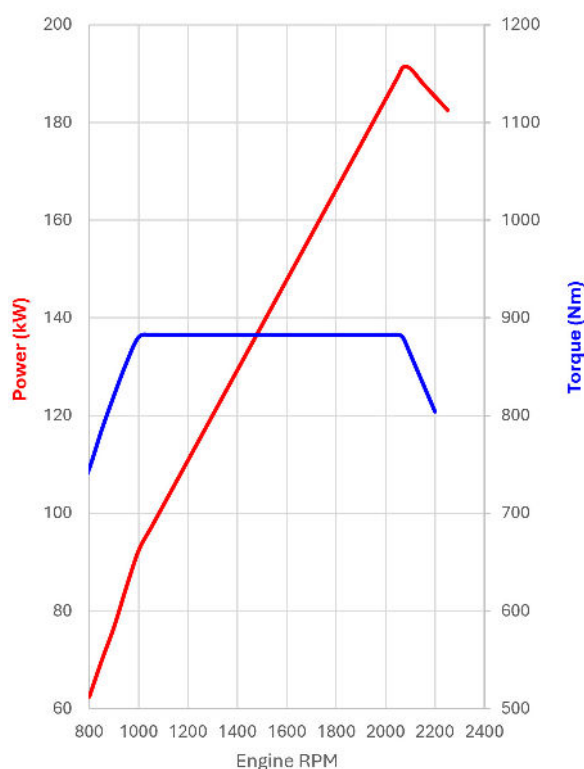

Transmission

Description: Allison LCT2500 GEN 6

Type: 6 speed automatic

Ratios:

AT	1	2	3	4	5	6	REV
	3.51	1.9	1.44	1	0.74	0.64	5.09

Power Take Off Facility: LHS and RHS PTO openings on transmission case. Torque converter turbine driven PTO drive gear.

Gearbox Transfer

Description: Isuzu TF56

4X4 Type: Full time 4WD with lockable centre differential

Ratio: High: 1.00, Low: 1.913

Technology & Equipment

Intelligent Safety

ACTIVE SAFETY	Advanced Emergency Braking (AEB)	
	Anti Lock Braking System (ABS)	
	Anti Skid Regulator (ASR)	
	Attention Alert System (AAS)	
	Auto Lighting System (ALS)	
	ADVANCED DRIVER ASSISTANCE SYSTEMS (ADAS)[^]	Cab Tilt Warning (CTW) on Single cab
		Distance Warning System (DWS)
		Electronic Stability Control (ESC)
		Forward Collision Warning (FCW)
	Lane Departure Warning (LDW)	
Traffic Movement Warning (TMW)		
PASSIVE SAFETY	Door Mounted Cornering Lamps	
	Driver and Front Left Hand Passenger Seatbelt Pretensioners	
	Driver and Front Passenger Airbags	
	CABIN OCCUPANT SAFETY SYSTEMS (COSS)	ECE-R29 Cab with Side Anti-Intrusion Beams
Overhead storage compartments with doors.		

Accessories

Protection	Isuzu Genuine Bull Bar*	●
	Isuzu Seat Covers	●
	Isuzu Floor Mats	●
	Isuzu Dash Mats	●
	Isuzu Weathershields	●
Technology	Isuzu Mudflaps	●
	Isuzu Cameras	●
Aerodynamics	Air Deflectors	●
	Warning Triangles	●
Safety	Wheel Nut Indicators	●
	Signage	●

* Expected to be available October 2025

● Fitted as Standard ● Option to Fit

Some options are provided via 3rd party retailer. Please discuss with your local Isuzu dealer.

Cabin Features

General Features

Engine Access	Single cab: Manual cab tilt to 45° with torsion bar assistance Crew cab: Electro-hydraulic cab tilt
Steps	Heavy duty anti slip steps
Doors	70° opening internally reinforced front doors
Mirrors	Heated & powered exterior main mirrors with flat glass and additional independently adjustable convex "spot" mirrors
Wipers	Auto windshield wiper system, wet wipers
Exterior Lighting	BI-LED Headlamps and Daytime Running Lamps
	Roof mounted clearance lamps
	Front LED foglamps LED tail lamps
Audible Warning	Reverse alarm
Front Bumper	3-piece resin, body coloured
Security	Single cab: Passive Entry and Start System (PESS) with remote central locking and immobiliser
	Crew cab: Central locking with remote keyless entry & immobiliser

Premium Isuzu Audio Visual Unit

Connectivity	Bluetooth
	USB socket
	WiFi with over-the-air updates
Radio	Input for up to 6 High Definition (HD) cameras (available accessory)
	AM / FM
Screen Type	8" High Definition with capacitive touch
Smartphone Integration*	Wireless Apple CarPlay®
	Wireless Android Auto™
	Wi-Fi connectivity
Navigation	Provided via smartphone application

CarPlay is a trademark of Apple Inc.
Android Auto is a trademark of Google LLC.



Cabin Interior

Air Conditioning	Auto control
Door Windows	Electric control
Entry Assist Grips	Door and roof pillar mounted
Interior Lighting	LED door open lamp. Bright LED room lamp
Power Outlet	24V cigarette lighter
Seatbelts	3-point lap sash seatbelts in all outboard seating positions. Centre seat lap belts.
	Isri 6860/875 NTS2 air suspension driver's seat with heating and ventilation
Seating	LH passenger bucket seat, plus centre seat with folding seat back and storage compartment.
Steering Column	Tilt / telescopic adjustable
Storage	Overhead compartments, two cup holders, front door pockets.

Driver Control

Engine	Cruise control
	DPD manual regeneration switch Idle speed control
General Controls	Auto windshield wiper system, wet wipers, washers, engine brake and turn signals
Safety Systems	AEB on/off, DWS on/off/sensitivity adjust, LDW on/off/sensitivity adjust, TMW on/off, ESC&ASR on off, headlamps and ALS on/off.
Steering Wheel Controls	Multi Information Display controls
	Audio Visual volume control
	Audio Visual seek controls
	Phone control ADAS controls

Instrumentation

General Instrumentation	Digital odometer with integrated dual tripmeters
	Engine coolant temperature and fuel level gauges
	Speedometer and tachometer
Multi Information Display	Adjustable vehicle speed warning
	AEB, FCW, DWS, LDW, TMW systems activation alerts
	Hourmeter
	Low fuel and AdBlue level alerts.
	Auto windshield wiper system mode
	Vehicle systems status

Chassis

Steering

Type	Power assisted recirculating ball
Lock Angle Inside	34°
Lock Angle Outside	29°

Suspension

Front	Single stage alloy steel taper leaf spring
	Double acting hydraulic shock absorbers. Stabiliser bar.
Rear	Type: Multi-leaf main spring, multi-leaf helper spring

Fuel Tank

Diesel Tank	Type: Frame mounted steel tank
	Maximum capacity²: 200L
	Fuel cap: Lockable cap
AdBlue® Tank	Type: Frame mounted high-density polyethylene tank
	Maximum capacity²: 65 L

Electrical Systems

Type	24 volt
Alternator	90 amp
Battery	2 x 115E41L (651 CCA) batteries connected in series
CAN Bus provision	FMS Provision

Chassis Frame

Type	Rivetless bolted ladder frame
Material	HT540 steel side members
Dimensions	Side rail (mm): 275 x 90 x 7.5 Rear frame width (mm): 870

Axles

Front	Description: Isuzu FD055
	Type: Single drive with Birfield outer joints
	Other features: Permanently engaged front hubs
	Capacity: 5,500 kg
Rear	Description: Isuzu R100
	Type: Single drive
	Other features: “No Spin” differential lock
	Capacity: 10,000 kg
	Ratio: 6.500

Wheels & Tyres

Front	Wheels: 22.5 x 7.5 ten stud ISO standard. Steel wheels
	Tyres: 11R 22.5 148/145M
	Steer axle tyre rating: 6,300 kg
Rear	Wheels: 22.5 x 7.5 ten stud ISO standard. Steel wheels
	Tyres: 11R 22.5 148/145M
	Rear axle tyre rating: 11,600 kg

Brakes

Type	Air over hydraulic dual circuit front and rear drum brakes.
Diameter Front	410 mm
Diameter Rear	410 mm
Park Brake	Spring park brake acting on all rear wheels

Weights & Dimensions

Weights (kg)

Models	Ratings ³		Loading Limit ³ (at ground)		Cab Chassis Weight ⁴			Model Code
	GVM	GCM	Front	Rear	Front	Rear	Total	
FTS 150.26 AT R43 4X4	15,000	18,500	5,500	10,000	3,430	2,340	5,770	FT2660
FTS 150.26 AT C43 4X4	15,000	18,500	5,500	10,000	3,665	2,385	6,050	FT2661

Dimensions (mm)

Models	WB	OAL	FOH	ROH	CA	RT	ORT	CH	FFH (Unladen)	RFH (Unladen)	EFH (Unladen)	Turning Circle Kerb to Kerb (m) ⁵
FTS 150.26 AT R43 4X4	4,250	7,405	1,255	1,900	3,439	1,820	2,425	3,030	1,165	1,189	1,200	17.53
FTS 150.26 AT C43 4X4	4,250	7,405	1,255	1,900	2,748	1,820	2,425	3,125	1,160	1,189	1,202	17.53

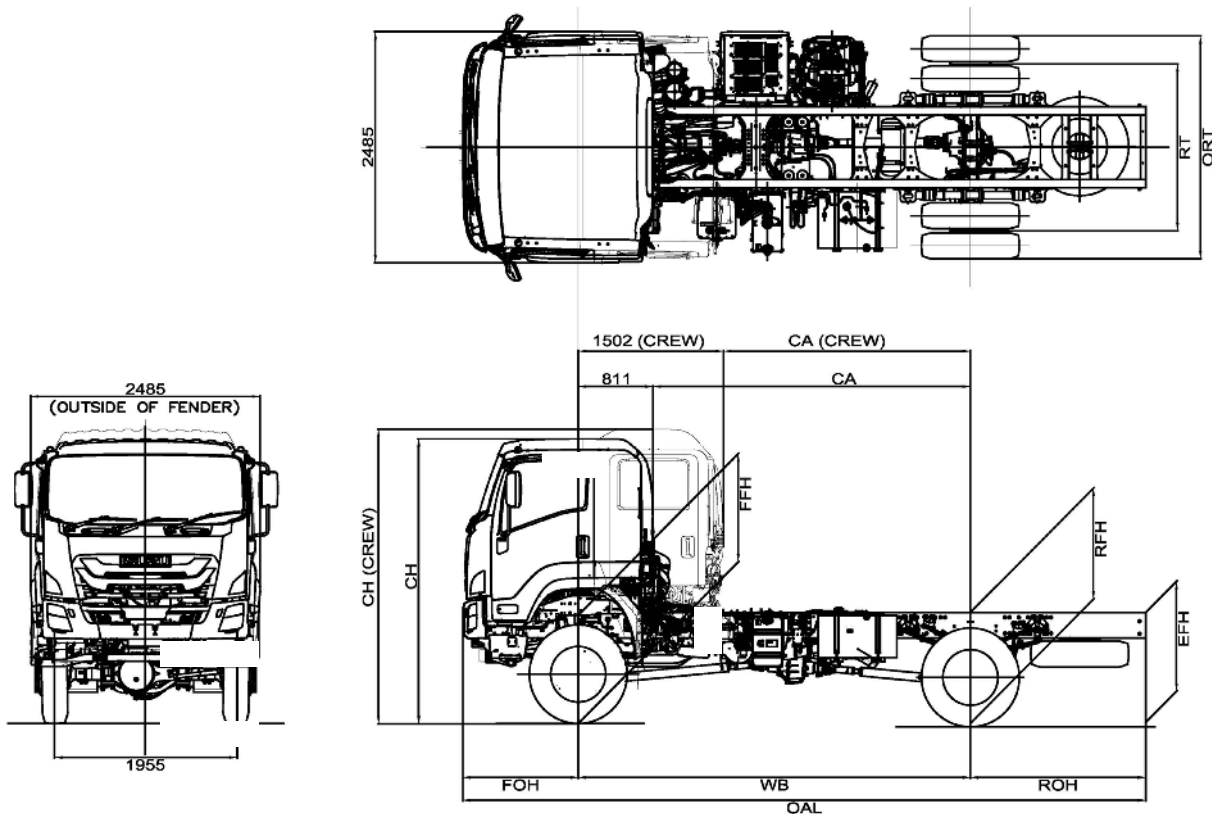

Cab Chassis drawing not representative of model

Service & Support



Dealer Network

Service & Support	National Isuzu Truck Dealer Network and Accredited Service Centres
	Find a Dealer Online

Find your local dealer
Scan QR Code



Warranty[#]

Chassis	3 Year Warranty [#] 150,000 km [#]
Genuine Parts & Accessories	2 Year Warranty or 50,000km [#] (When installed by an Isuzu Trucks Approved Dealership - Including Labor)



[#] 3 Year Warranty (36 months / 150,000kms) cover is 36 months or 150,000kms, whichever comes first. Cab Perforation Corrosion is limited to 36 months / unlimited kms on all models.
² As shown on fuel tank. Volume of fuel that can be added to a near-empty tank will vary according to operating conditions.
³ Vehicle ratings and axle weight limits are subject to government regulatory requirements and weight distribution analysis. Consult your Isuzu dealer to select the correct vehicle for your specific application.
⁴ Cab chassis only as supplied and including 100% fuel, 100% AdBlue, tools, and spare wheel (if applicable).
⁵ Turning circle dimensions are based on manufacturers calculations and may vary under real-world conditions.
 The information in this spec sheet was correct at time of printing, but all measurements, specifications and equipment are subject to change without notice. Some equipment may have been changed and/or is available at extra cost. Isuzu New Zealand (INZ) may make changes at any time without notice, in prices, colours, materials, equipment and models. INZ makes all reasonable attempts to ensure the availability of all vehicles and equipment. The information in this spec sheet is general in nature. Your Isuzu dealer can confirm all measurements, specifications and vehicle / equipment availability upon request. To the extent permitted by the law, INZ is not liable to any person as result of reliance on the content of this spec sheet.
⁶ Advance Driver Assistance Systems are intended to support the driver but are not a replacement for safe driving practices.
^{*} Smartphone Integration compatible with selected apps and the latest smartphone versions of iOS and Android. Active data service is required for some functionality. For USB connections, a connection cable is sold separately.

