



Specification Guide

FVL 240.30 / 180.30

Weight Rating

GVM	24,000 / 18,000 kg
GCM	27,500 / 21,500 kg

Engine

Power	221 kW @ 2,200 rpm
Torque	981 Nm @ 1000 - 2100 rpm

Transmission

6 speed automatic transmission (AT)

Wheelbase

6,655 mm

Key Features

- ADR 80/04 (Euro VI) Compliant
- Advanced Emergency Braking (AEB)
- Full Speed Adaptive Cruise Control (FACC)
- Electronic Stability Control (ESC)
- ECE-R29 cab with side anti-intrusion beams
- Isri 6860/875 NTS2 Air Suspension Driver's Seat
- Bi-LED Headlamps with Daytime Running Lamps



Truck Finder

Scan to search, view and download full spec sheets for all Isuzu truck models.

ISUZU
TRUCKS

Driveline

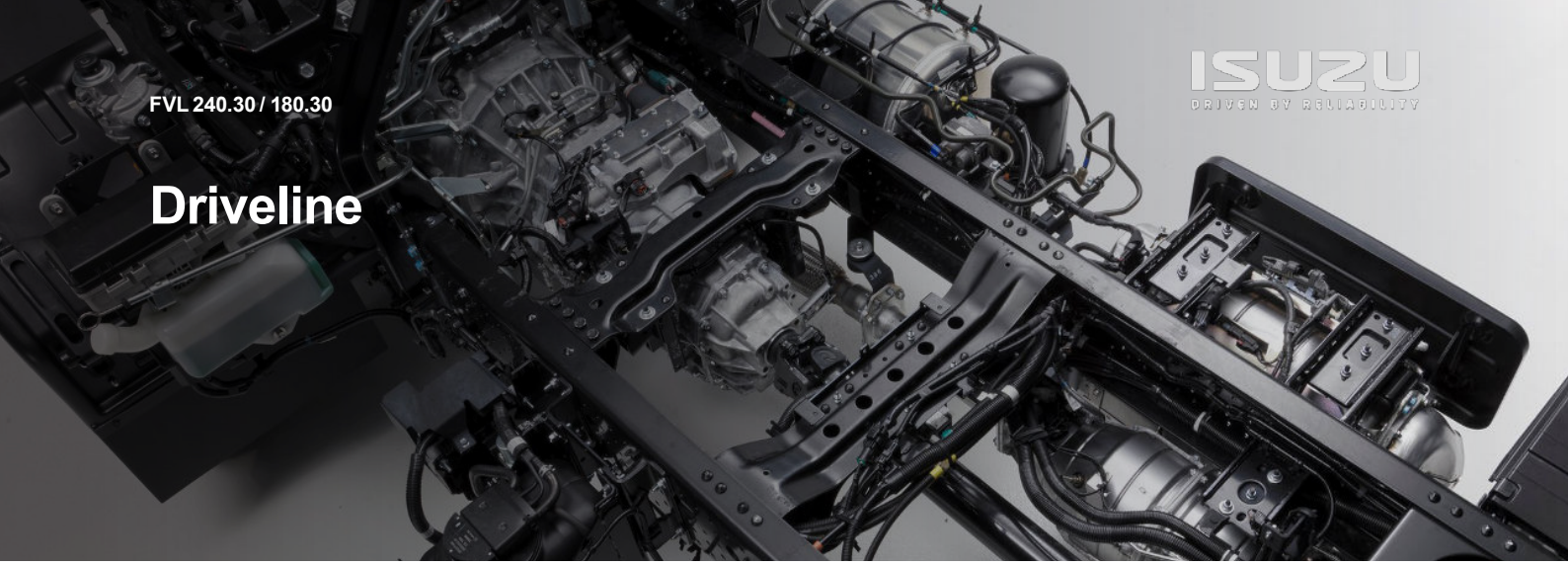

Engine

Description	Isuzu DB6A-TCC
Type	6 cylinder
Power	221 kW (300PS) @ 2,200 rpm (DIN NET)
Torque	981 Nm @ 1,000 - 2,100 rpm (DIN NET)
Displacement	6,690 cc
Bore x Stroke	107 mm x 124 mm
Induction	Turbocharger with air-to air intercooler
Fuel Injection	Direct injection high pressure common rail system
Emission Standard	ADR 80/04 (Euro VI) compliant
Emission Control	SCR (Selective Catalytic Reduction) DPD (Diesel Particulate Diffuser).
Auxiliary Brake	Engine Compression Brake (I-Brake)

DB6A-TCC 300PS Euro-VI

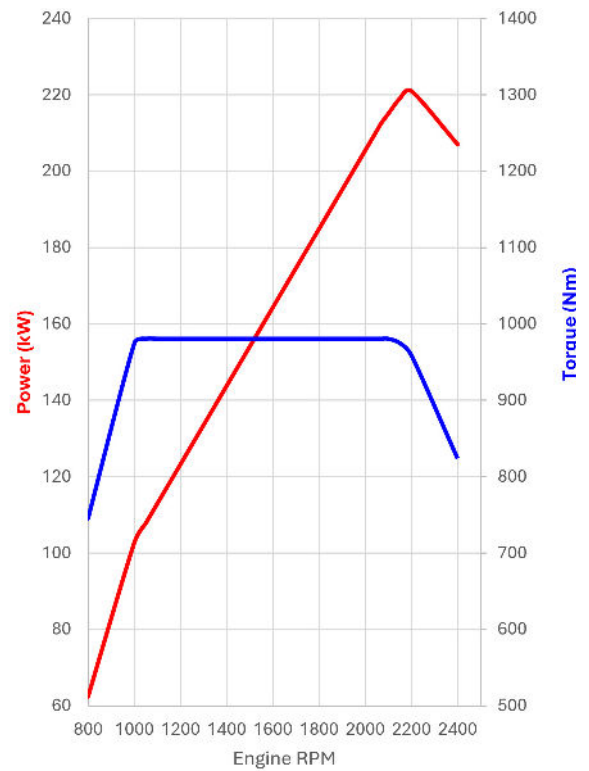

Transmission

Description: Allison 3500 GEN 6

Type: 6 speed automatic

Ratios:

AT	1	2	3	4	5	6	REV
	4.59	2.25	1.54	1.00	0.75	0.65	5.00

Power Take Off Facility: LHS and top openings on transmission bellhousing.
Engine driven PTO drive gear.

Technology & Equipment

Intelligent Safety

ACTIVE SAFETY	Advanced Emergency Braking (AEB)
	Adaptive Driving Beam (ADB)
	Anti Lock Braking System (ABS)
	Anti Skid Regulator (ASR)
	Attention Alert System (AAS)
	Auto Lighting System (ALS)
	Cab Tilt Warning (CTW)
	Customisable Speed Limiter (CSL)
	Distance Warning System (DWS)
	Electronic Stability Control (ESC)
	Forward Collision Warning (FCW)
	Full Speed Adaptive Cruise Control (FACC)
	Intelligent Speed Limiter (ISL)
	Lane Departure Warning (LDW)
Traffic Movement Warning (TMW)	
Traffic Sign Recognition (TSR)	
PASSIVE SAFETY	Door Mounted Cornering Lamps
	Driver and Front Left Hand Passenger Seatbelt Pretensioners
	Driver and Front Passenger Airbags
	ECE-R29 Cab with Side Anti-Intrusion Beams
CABIN OCCUPANT SAFETY SYSTEMS (COSS)	Overhead storage compartments with doors.

Accessories

Protection	Isuzu Genuine Bull Bar	●
	Isuzu Seat Covers	●
	Isuzu Floor Mats	●
	Isuzu Dash Mats	●
	Isuzu Weathershields	●
	Isuzu Mudflaps	●
Technology	Isuzu Cameras	●
Aerodynamics	Air Deflectors	●
	Warning Triangles	●
Safety	Wheel Nut Indicators	●
	Signage	●

● Fitted as Standard ● Option to Fit

Some options are provided via 3rd party retailer. Please discuss with your local Isuzu dealer.

Cabin Features

General Features

Engine Access	Electro-hydraulic cab tilt to 45 degrees
Steps	Heavy duty anti slip steps
Doors	70° opening internally reinforced front doors
Mirrors	Heated & powered exterior main mirrors with flat glass and additional independantly adjustable convex "spot" mirrors
Wipers	Auto windshield wiper system, wet wipers
Exterior Lighting	BI-LED Headlamps with Adaptive Driving Beam (ADB) and Daytime Running Lamps
	Roof mounted clearance lamps
	Front LED foglamps
	LED tail lamps
Audible Warning	Reverse alarm
Front Bumper	3-piece resin, body coloured
Security	Passive Entry and Start System (PESS) with remote Central locking and Immobiliser

Premium Isuzu Audio Visual Unit

Connectivity	Bluetooth
	USB socket
Radio	WiFi with over-the-air updates
	Input for up to 6 High Definition (HD) cameras (available accessory)
Screen Type	AM / FM
Smartphone Integration*	8" High Definition with capacitive touch
	Wireless Apple CarPlay®
	Wireless Android Auto™
Navigation	Wi-Fi connectivity
	Provided via smartphone application

CarPlay is a trademark of Apple Inc.
Android Auto is a trademark of Google LLC.



Cabin Interior

Air Conditioning	Auto control
Door Windows	Electric control
Entry Assist Grips	Door and roof pillar mounted
Interior Lighting	LED door open lamp. Bright LED room lamp
Power Outlet	24V
Seatbelts	3-point lap sash seatbelts in all outboard seating positions. Centre seat lap belts.
Seating	Isri 6860/875 NTS2 air suspension driver's seat with heating and ventilation LH passenger bucket seat, plus centre seat with folding seat back and storage compartment.
Steering Column	Tilt / telescopic adjustable
Storage	Overhead shelf, two cup holders, front door pockets

Driver Control

Engine	Full speed adaptive cruise control DPD manual regeneration switch Idle speed control
General Controls	Auto windshield wiper system, wet wipers, washers, engine brake and turn signals
Safety Systems	AEB on/off, DWS on/off/sensitivity adjust, LDW on/off/sensitivity adjust, TMW on/off, ESC&ASR on off, headlamps and ALS on/off.
Steering Wheel Controls	Multi Information Display controls Audio Visual volume control Audio Visual seek controls Phone control ADAS controls

Instrumentation

General Instrumentation	Digital odometer with integrated dual tripmeters Engine coolant temperature and fuel level gauges Speedometer and tachometer Adjustable vehicle speed warning AEB, FCW, DWS, LDW, TMW systems activation alerts
Multi Information Display	CTW indicator Hourmeter Low fuel and AdBlue level alerts. Auto windshield wiper system mode Vehicle systems status

Chassis

Steering

Type	Electric power steering
Lock Angle Inside	48.5°
Lock Angle Outside	33°

Suspension

Front	Single stage alloy steel taper leaf spring
	Double acting hydraulic shock absorbers. Stabiliser bar.
Rear	Description: Hendrickson HAS460
	Type: Airbag
	Capacity: 20,000kg

Fuel Tank

Diesel Tank	Type: Frame mounted steel
	Maximum capacity²: 400 L with fuel cooler
	Fuel cap: Lockable cap
AdBlue[®] Tank	Type: Frame mounted high-density polyethylene tank
	Maximum capacity²: 65 L

Electrical Systems

Type	24 volt
Alternator	90 amp
Battery	2 x 115E41L (651 CCA) batteries connected in series

Chassis Frame

Type	Rivetless bolted ladder frame
Material	HT540
Dimensions	Side rail (mm): 90 x 305 x 8.0 Rear frame width (mm): 870

Axles

Front	Description: Meritor MFS73
	Type: Reverse Elliot I-beam
	Capacity: 7,300 kg
Rear	Drive Axle: Meritor RS-23-161G
	Lazy Axle: Meritor TR4670
	Type: Single drive + lazy axle combination
	Capacity: 19,000 kg
	Ratio: 5.625

Wheels & Tyres

Front	Wheels: 22.5 x 8.25 ten stud steel wheels
	Tyres: 275/70R22.5 148/145L
	Front axle tyre rating: 6,300kg
Rear	Wheels: 22.5 x 8.25 ten stud steel wheels
	Drive axle tyres: 275/70R22.5 148/145L
	Lazy axle tyres: 275/70R22.5 148/145L
	Rear axle tyre rating: 23,200kg

Brakes

Type	Full air dual circuit, disc brake with EBS
Diameter Front	434 mm
Diameter Rear	434 mm
Park Brake	Spring park brake acting on all rear wheels

Weights & Dimensions

Weights (kg)

Models	Ratings ³		Loading Limit ³ (at ground)		Cab Chassis Weight ⁴			Model Code
	GVM	GCM	Front	Rear	Front	Rear	Total	
FVL 240.30 AT R67	24,000	27,500	6,300	19,000	3,669	3,584	7,253	FV2664
FVL 180.30 AT R67	18,000	21,500	6,300	19,000	3,669	3,584	7,253	FV2663*

*De-rated model code. Dealer should order original model code and request de-rate upon arrival

Dimensions (mm)

Models	WB	OAL	FOH	ROH	CA	RT	ORT	CH	FFH (Unladen)	RFH (Unladen)	EFH (Unladen)	Turning Circle Kerb to Kerb (m) ⁵
FVL 240.30 AT R67	6,655	11,755	1,255	3,160	5,844	1,840	2,450	2,894	995	1,005	1,005	24.44
FVL 180.30 AT R67	6,655	11,755	1,255	3,160	5,844	1,840	2,450	2,894	995	1,005	1,005	24.44

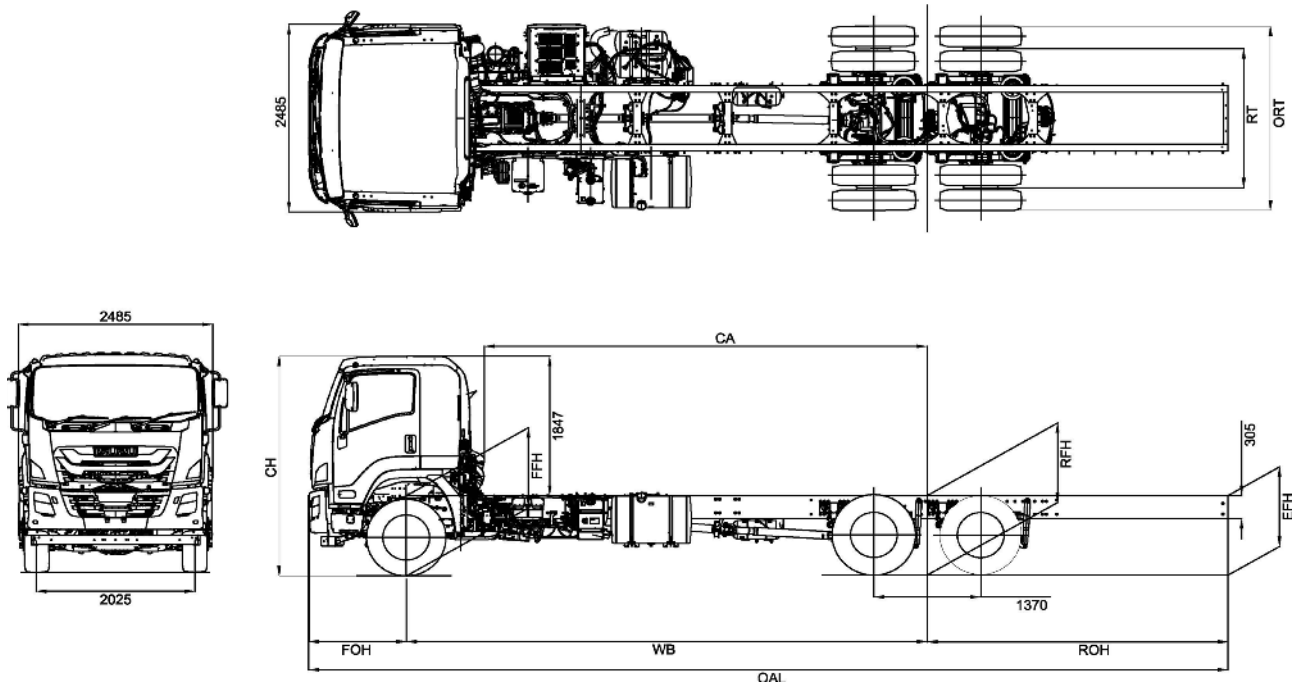

Cab Chassis drawing not representative of model

Service & Support



Dealer Network

Service & Support	National Isuzu Truck Dealer Network and Accredited Service Centres
	Find a Dealer Online

Warranty#

Chassis	5 Year Warranty#
	350,000 km#
Genuine Parts & Accessories	2 Year Warranty or 50,000km# (When installed by an Isuzu Trucks Approved Dealership - Including Labor)

Find your local dealer
Scan QR Code



Total 5 Year Warranty, including Base Warranty (36 months / 200,000kms) and Additional Warranty (24 months / 150,000kms), cover is 60 months or 350,000kms, whichever comes first. To qualify for Additional Warranty, all scheduled servicing during the Base and Additional Warranty periods (ie. the total 60 months) must be performed by an authorised Isuzu service dealer from the date of delivery to the first customer. If scheduled servicing is performed by unauthorized service providers, only the Base Warranty will apply. Tipper bodies are excluded from Additional Warranty. These are covered by Base Warranty only.

² As shown on fuel tank. Volume of fuel that can be added to a near-empty tank will vary according to operating conditions.

³ Vehicle ratings and axle weight limits are subject to government regulatory requirements and weight distribution analysis. Consult your Isuzu dealer to select the correct vehicle for your specific application.

⁴ Cab chassis only as supplied and including 100% fuel, 100% AdBlue, tools, and spare wheel (if applicable).

⁵ Turning circle dimensions are based on manufacturers calculations and may vary under real-world conditions.

The information in this spec sheet was correct at time of printing, but all measurements, specifications and equipment are subject to change without notice. Some equipment may have been changed and/or is available at extra cost. Isuzu New Zealand (INZ) may make changes at any time without notice, in prices, colours, materials, equipment and models. INZ makes all reasonable attempts to ensure the availability of all vehicles and equipment. The information in this spec sheet is general in nature. Your Isuzu dealer can confirm all measurements, specifications and vehicle / equipment availability upon request. To the extent permitted by the law, INZ is not liable to any person as result of reliance on the content of this spec sheet.

[^]Advance Driver Assistance Systems are intended to support the driver but are not a replacement for safe driving practices.

*Smartphone Integration compatible with selected apps and the latest smartphone versions of iOS and Android. Active data service is required for some functionality. For USB connections, a connection cable is sold separately.

