



All images displayed in this document are for illustrative purposes only.

## Specification Guide

# NMR TRI-TIPPER 60.15

### Weight Rating

**GVM** 5,995 kg

**GCM** 8,000 kg - 9,500 kg

### Engine

**Power** 110 kW @ 2,800 rpm

**Torque** 375 Nm @ 1,280 - 2,800 rpm

### Transmission

6 speed manual transmission (MT)

9 speed dual clutch transmission (DT)

### Wheelbase

2,490 mm

### Body

Factory fitted tri-lift tipper

### Key Features

- ADR 80/04 (pPNLT) Compliant
- Advanced Emergency Braking (AEB)
- Bi-LED Headlamps with Daytime Running Lamps
- ECE-R29 cab with side anti-intrusion beams
- Electronic Stability Control (ESC)
- Lane Departure Warning (LDW)
- Full Speed Adaptive Cruise Control (FACC)\*\*
- Tri-Lift tipper - tilts 3 ways
- LHS and RHS rope rails
- Cubic volume: 2.0m<sup>3</sup>
- Auto release body lockdown hook

\*\* Dual Clutch transmission only



### Truck Finder

Scan to search, view and download full spec sheets for all Isuzu truck models.

**ISUZU**  
TRUCKS

# Driveline

## Engine

<b>Description</b>	Isuzu 4JZ1-TCS
<b>Type</b>	4 cylinder
<b>Power</b>	110 kW (150PS) @ 2,800 rpm
<b>Torque</b>	375 Nm @ 1,280 - 2,800 rpm
<b>Displacement</b>	2,999 cc
<b>Bore x Stroke</b>	95.4 mm x 104.9 mm
<b>Induction</b>	Electronically controlled variable nozzle turbocharger with air-to air intercooler.
<b>Fuel Injection</b>	Direct injection high pressure common rail system
<b>Emission Standard</b>	ADR 80/04 (pPNLT) compliant
<b>Emission Control</b>	SCR (Selective Catalytic Reduction) DPD (Diesel Particulate Diffuser) EGR (Exhaust Gas Recirculation)
<b>Auxiliary Brake</b>	Vacuum controlled exhaust brake

## 4JZ1-TCS 150PS pPNLT

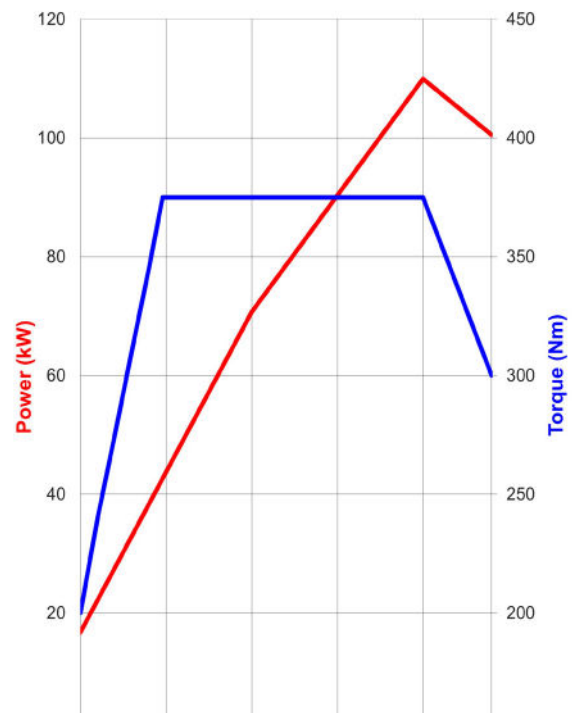

## Transmission

<b>Description:</b> ISUZU MYY-6Z	
<b>Type:</b> 6 speed manual with synchromesh on gears 2 - 6	
<b>Ratios:</b>	
<b>MT</b>	1 2 3 4 5 6 REV
	5.97 3.43 2.04 1.37 1.00 0.70 5.70
<b>Power Take Off Facility:</b> Provision on LHS of transmission case. Drive from counter gear.	
<b>Description:</b> ISUZU MYR-9S	
<b>Type:</b> 9 speed dual clutch transmission with both fully automatic and clutchless manual operation modes	
<b>Ratios:</b>	
<b>DT</b>	1 2 3 4 5 6 7 8 9 REV
	5.16 3.94 2.86 2.18 1.67 1.30 1.00 0.76 0.58 6.61
<b>Power Take Off Facility:</b> Provision on LHS of transmission case. Driven from counter gear.	

## Clutch

<b>Type:</b> Single plate with auto adjusting hydraulic control and vacuum assistance	
<b>MT</b>	Clutch Plate Diameter: 300 mm
	Clutch Lining Area: 847 cm <sup>2</sup>
<b>DT</b>	<b>Type:</b> Fully automated dual wet clutch and torque converter (TC) with lock up

# Technology & Equipment

## Intelligent Safety

<b>ACTIVE SAFETY</b>  <b>ADVANCED DRIVER ASSISTANCE SYSTEMS (ADAS)^</b>	Advanced Emergency Braking (AEB)
	Anti Lock Braking System (ABS)
	Anti Skid Regulator (ASR)
	Attention Alert System (AAS)
	Auto Lighting System (ALS)
	Distance Warning System (DWS)
	Electronic Stability Control (ESC)
	Electronic Park Brake (EPB)
	Electronic Brakeforce Distribution (EBD)
	Front Cross Traffic Alert (FCTA)
	Full Speed Adaptive Cruise Control (FACC)**
	Intelligent Speed Limiter (ISL)
	Intersection Emergency Braking (IEB)
	Intersection Warning System (IWS)
	Lane Departure Warning (LDW)
	Miss Acceleration Mitigation (MAM)**
	Traffic Movement Warning (TMW)
Traffic Sign Recognition (TSR)**	
<b>PASSIVE SAFETY</b>  <b>CABIN OCCUPANT SAFETY SYSTEMS (COSS)</b>	Driver and Front Left Hand Passenger Seatbelt Pretensioners
	Driver and Front Passenger Airbags
	ECE-R29 Cab with Side Anti-Intrusion Beams
	Door mounted cornering lamps
	Overhead shelf restraint netting

\*\*Available with DT only

## Accessories

	Isuzu Genuine Bull Bar	●
	Isuzu Seat Covers	●
	Isuzu Floor Mats	●
<b>Protection</b>	Isuzu Dash Mats	●
	Isuzu Mudflaps	●
	Isuzu Cameras	●
<b>Technology</b>	Air Deflectors	●
	Warning Triangles	●
<b>Aerodynamics</b>	Wheel Nut Indicators	●
	Signage	●

● Fitted as Standard      ● Option to Fit

Some options are provided via 3rd party retailer. Please discuss with your local Isuzu dealer.

# Cabin Features

## General Features

<b>Audible Warning</b>	Reverse alarm
<b>Engine Access</b>	Manual cab tilt to 45° with torsion bar assistance
<b>Steps</b>	Heavy duty anti slip steps
<b>Mirrors</b>	Pillar mounted heated mirrors with electric folding (manual mirror adjustment)
<b>Wipers</b>	Two speed windscreen wipers with intermittent wipe mode
<b>Exterior Lighting</b>	BI-LED Headlamps with LED Daytime Running Lamps (DRL) LED tail lamps
<b>Front Bumper</b>	3-piece resin, body coloured
<b>Security</b>	Remote central locking and immobiliser

## Premium Isuzu Audio Visual Unit

<b>Connectivity</b>	Bluetooth
	USB socket
	WiFi with over-the-air updates
	Input for up to 6 High Definition (HD) cameras (available accessory)
<b>Radio</b>	AM / FM
<b>Screen Type</b>	8" High Definition with capacitive touch
<b>Smartphone Integration*</b>	Wireless Apple CarPlay®
	Wireless Android Auto™
	Wi-Fi connectivity
<b>Navigation</b>	Provided via smartphone application

CarPlay is a trademark of Apple Inc.  
Android Auto is a trademark of Google LLC.



## Cabin Interior

<b>Air Conditioning</b>	Auto climate control
<b>Door Windows</b>	Electric control
<b>Entry Assist Grips</b>	Door and roof pillar mounted
<b>Interior Lighting</b>	LED lamp
<b>Power Outlet</b>	24V cigarette lighter
<b>Seatbelts</b>	3-point lap sash seatbelts in all outboard seating positions. Centre seat lap belts.
<b>Seating</b>	Driver's bucket seat
	Passenger benchseat with 2 seat capacity
<b>Steering Column</b>	Tilt / telescopic adjustable
<b>Storage</b>	Overhead cabinet, two cup holders, door pockets

## Driver Control

	Full speed adaptive cruise control**
<b>Engine</b>	DPD manual regeneration switch
	Idle speed control
<b>General Controls</b>	Windscreen wipers (2 speed and intermittent modes), washers, exhaust brake, turn signals
<b>Safety Systems</b>	AEB on/off, DWS on/off/sensitivity adjust, LDW on/off/sensitivity adjust, TMW on/off, ESC&ASR on off, headlamps and ALS on/off.
<b>Steering Wheel Controls</b>	Multi Information Display controls
	Audio Visual volume control
	Audio Visual seek controls
	Phone control ADAS controls
<b>Transmission (DT Only)</b>	Gear selection control with P-R-N-D and sequential shift positions

\*\*Available with DT only

## Instrumentation

<b>General Instrumentation</b>	Digital odometer with integrated dual tripmeters
	Engine coolant temperature and fuel level gauges
	Speedometer and tachometer
<b>Multi Information Display</b>	Adjustable vehicle speed warning
	AEB, FCW, DWS, LDW, TMW systems activation alerts
	CTW indicator
	Hourmeter
	Vehicle systems status

# Chassis

## Steering

<b>Type</b>	Power assisted rack and pinion
<b>Turns Lock To Lock</b>	4.20
<b>Lock Angle Inside</b>	38 °
<b>Lock Angle Outside</b>	36 °

## Suspension

<b>Front</b>	<b>Type:</b> Coil springs <b>Other Features:</b> Double acting hydraulic shock absorbers
<b>Rear</b>	<b>Type:</b> Multi leaf main spring, taper leaf helper spring <b>Other Features:</b> Double acting hydraulic shock absorbers

## Fuel Tank

<b>Diesel Tank</b>	<b>Type:</b> Frame mounted tank <b>Maximum capacity<sup>2</sup>:</b> 70L <b>Fuel cap:</b> Lockable cap
<b>AdBlue<sup>®</sup> Tank</b>	<b>Type:</b> Frame mounted high-density polyethylene tank <b>Maximum capacity<sup>2</sup>:</b> 14 L

## Electrical Systems

<b>Type</b>	24 volt
<b>Alternator</b>	90 amp
<b>Battery</b>	2 x 80D26L (600 CCA) batteries connected in series
<b>CAN Bus provision</b>	FMS Provision

## Tipper body

<b>Type</b>	All steel body with auto release drop sides. Tri-tipper with 3-way tilt - left side, right side, or rear
<b>Other features</b>	Auto release body lockdown hook Shovel rack LHS and RHS rope rails Non-slip side steps 20 second rise / 20 second lower time
<b>Capacity</b>	2.0m <sup>3</sup>
<b>Dimensions (mm) (inside)</b>	3,050 x 1,770 x 370
<b>Material thickness (mm)</b>	Deck plate: 3.2 Side / front / tail plate: 2.3

## Chassis Frame

<b>Type</b>	Cold rivetted ladder frame
<b>Material</b>	JSH440 steel
<b>Dimensions</b>	Side rail (mm): 65 x 180 x 5.3 Rear frame width (mm): 700

## Axles

<b>Front</b>	<b>Description:</b> Isuzu FI026 <b>Type:</b> Independent wishbone <b>Capacity:</b> 2,600 kg
<b>Rear</b>	<b>Description:</b> Isuzu R050 <b>Type:</b> Full floating banjo with four differential pinions <b>Capacity:</b> 5,000 kg <b>Ratio:</b> 5.125 (MT), 5.375 (DT)

## Wheels & Tyres

<b>Front</b>	<b>Wheels:</b> 16 x 5.5J five stud steel wheels <b>Tyres:</b> 205/85R16 117/115L <b>Steer axle tyre rating:</b> 2,570 kg
<b>Rear</b>	<b>Wheels:</b> 16 x 5.5J five stud steel wheels <b>Tyres:</b> 205/85R16 117/115L <b>Rear axle tyre rating:</b> 4,860 kg

## Brakes

<b>Type</b>	Ventilated disc/disc with dual circuit hydraulic control, and integrated boost assist
<b>Diameter Front</b>	293 mm
<b>Diameter Rear</b>	293 mm
<b>Park Brake</b>	190mm Diameter drum mounted on rear of transmission

# Weights & Dimensions

## Weights (kg)

Models	Ratings <sup>3</sup>		Loading Limit <sup>3</sup> (at ground)		Cab Chassis Weight <sup>4</sup>			Model Code
	GVM	GCM	Front	Rear	Front	Rear	Total	
NMR 60.15 MT D25 TTP	5,995	9,500	2,570	4,860	1,762	1,467	3,229	NM2605
NMR 60.15 DT D25 TTP	5,995	8,000	2,570	4,860	1,792	1,477	3,269	NM2606

## Dimensions (mm)

Models	WB	OAL	FOH	ROH	CA	RT	ORT	CH	Turning Circle Kerb to Kerb (m) <sup>5</sup>
NMR 60.15 MT D25	2,490	4,835	1,100	1,245	2,027	1,425	1,865	2,175	8.47
NMR 60.15 DT D25	2,490	4,835	1,100	1,245	2,027	1,425	1,865	2,175	8.47

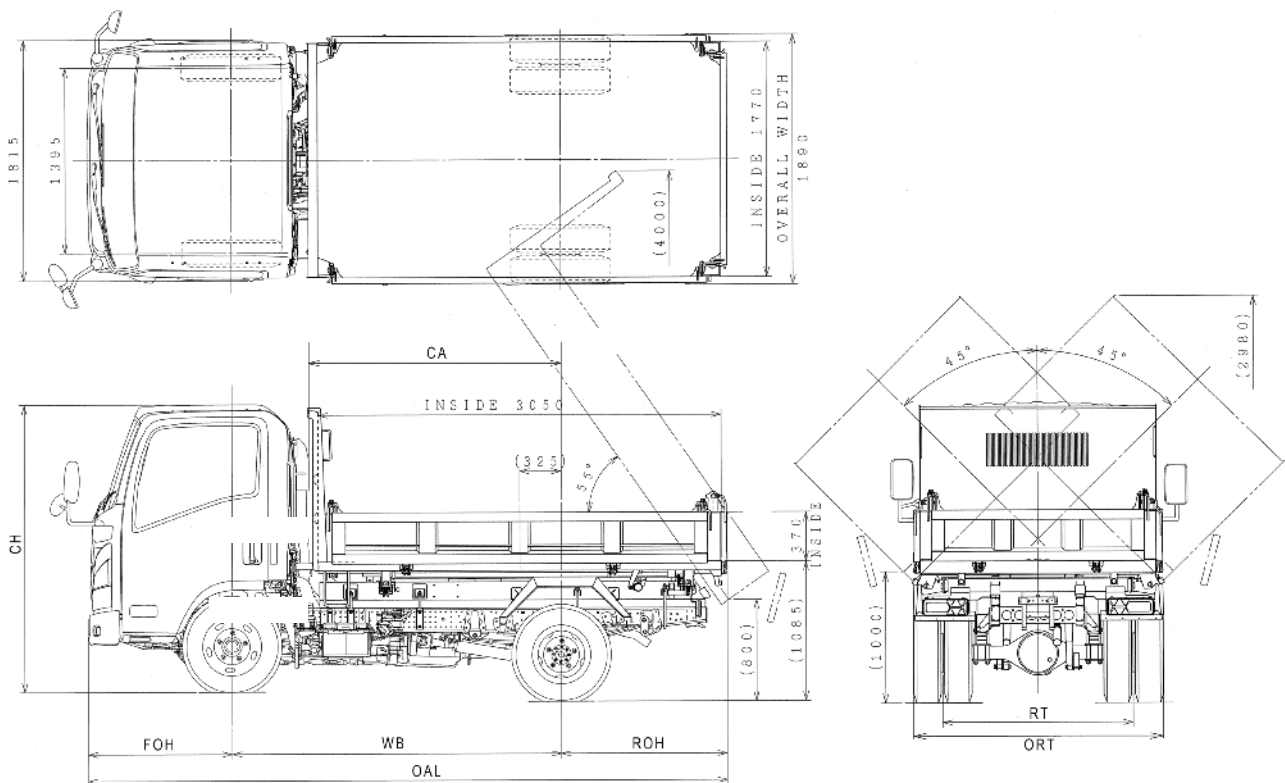

Drawing for reference only. Refer to the Isuzu Body Builder Guide for details.

# Service & Support



## Dealer Network

<b>Service &amp; Support</b>	National Isuzu Truck Dealer Network and Accredited Service Centres
	<a href="#">Find a Dealer Online</a>

Find your local dealer  
Scan QR Code



## Warranty<sup>#</sup>

<b>Chassis</b>	5 Year Warranty <sup>#</sup> 250,000 km <sup>#</sup>
<b>Genuine Parts &amp; Accessories</b>	2 Year Warranty or 50,000km <sup>#</sup> (When installed by an Isuzu Trucks Approved Dealership - Including Labor)



<sup>#</sup> Total 5 Year Warranty, including Base Warranty (36 months / 100,000kms) and Additional Warranty (24 months / 150,000kms), cover is 60 months or 250,000kms, whichever comes first. To qualify for Additional Warranty, all scheduled servicing during the Base and Additional Warranty periods (ie. the total 60 months) must be performed by an authorised Isuzu service dealer from the date of delivery to the first customer. If scheduled servicing is performed by unauthorised service providers, only the Base Warranty will apply. Tipper bodies are excluded from Additional Warranty. These are covered by Base Warranty only.

<sup>2</sup> As shown on fuel tank. Volume of fuel that can be added to a near-empty tank will vary according to operating conditions.

<sup>3</sup> Vehicle ratings and axle weight limits are subject to government regulatory requirements and weight distribution analysis. Consult your Isuzu dealer to select the correct vehicle for your specific application.

<sup>4</sup> Cab chassis only as supplied including 90% fuel and tools/spare wheel (if applicable).

<sup>5</sup> Turning circle dimensions are based on manufacturers calculations and may vary under real-world conditions.

The information in this spec sheet was correct at time of printing, but all measurements, specifications and equipment are subject to change without notice. Some equipment may have been changed and/or is available at extra cost. Isuzu New Zealand (INZ) may make changes at any time without notice, in prices, colours, materials, equipment and models. INZ makes all reasonable attempts to ensure the availability of all vehicles and equipment. The information in this spec sheet is general in nature. Your Isuzu dealer can confirm all measurements, specifications and vehicle / equipment availability upon request. To the extent permitted by the law, INZ is not liable to any person as result of reliance on the content of this spec sheet.

<sup>^</sup>Advance Driver Assistance Systems are intended to support the driver but are not a replacement for safe driving practices.

\*Smartphone Integration compatible with selected apps and the latest smartphone versions of iOS and Android. Active data service is required for some functionality. For USB connections, a connection cable is sold separately.

